

BOTTLE COOLER (32°F)

Model: CBC95-DC

95" Deep Chill Bottle Cooler

Textured baked black enamel finish exterior with all stainless steel countertop and slide lids, heavy duty galvanized interior.

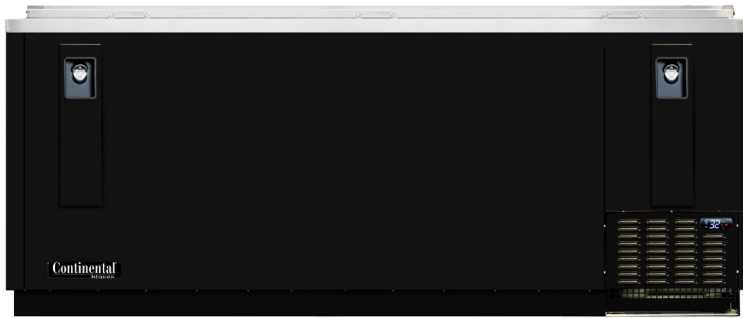

Options and Accessories

(upcharge and lead times may apply)

Stainless steel interior	Automatic, electric condensate evaporator
Additional wire bin dividers	Casters
Lid locks	Adjustable legs
Expansion valve system	

Consult factory for other model configurations, options and accessories.

Project Name:

Model Specified:

Location:

Item No:

Quantity:

AIA #:

SIS #:

Standard Model Features

REFRIGERATION SYSTEM

Environmentally safe R-134a refrigerant

Performance rated refrigeration system

Automatic, energy saving, non-electric condensate evaporator

Full length, extra large coil

Easily accessible and serviceable slide out condensing unit

CABINET ARCHITECTURE

High density, non-CFC polyurethane foamed-in-place insulation

Heavy duty, epoxy coated, adjustable steel wire storage bin dividers

Front, rear and side venting louvers

MODEL FEATURES

(2) Heavy duty cap openers with extra capacity, removable cap catcher

Easily accessible, front mounted cleanout drainage hose

Electronic controller with digital display

Continental
Refrigerator

Toll-Free: 800-523-7138
Phone: 215-244-1400
Fax: 215-244-9579

539 Dunksferry Road
Bensalem, PA 19020
www.continentalrefrigerator.com

APPROVAL:

Model Specifications

DIMENSIONAL DATA

Net Capacity (cubic feet)	32 (906 cu l)
12 oz. Bottle Capacity (# cases)	40
12 oz. Can Capacity (# cases)	59
Width, Overall (inches)	95 (2413 mm)
Depth, Overall (inches) (including bumpers & cap catcher)	29 1/8 (740 mm)
Height, Overall (inches)	33 1/2 (851 mm)
Number of Slide Lids	3
Number of Bin Dividers	8

REFRIGERANT DATA

Condensing Unit Size (H.P.)	1/2
Capacity (BTU per hour)*	3100

ELECTRICAL DATA

Voltage (International)	115/60/1 (220/50/1)
Feed Wires (including ground)	3
Total Amps (International)	10.7 (7.5)
Defrost Amps (International)	6.1 (3.2)
10 ft. Cord/Plug [attached] (International)	Yes (No)

SHIPPING DATA

Weight - (pounds)	535 (243 kg)
Height - Crated (inches)	39 (991 mm)
Width - Crated (inches)	102 3/4 (2610 mm)
Depth - Crated (inches)	30 1/4 (768 mm)

* Rating @ +20°F evaporator, 90°F ambient
Figures in parentheses reflect metric equivalents rounded to the nearest whole unit.



Equipped with one NEMA-5-15P Plug
(varies by country)

Continental[®]

Refrigerator

Toll-Free: 800-523-7138
Phone: 215-244-1400
Fax: 215-244-9579

539 Dunksferry Road
Bensalem, PA 19020
www.continentalrefrigerator.com

Due to our continued efforts in developing innovative products, specifications subject to change without notice.



© Copyright 2021. Continental Refrigerator.
A Division of National Refrigeration & Air Conditioning Products, Inc.

Model Plan Views

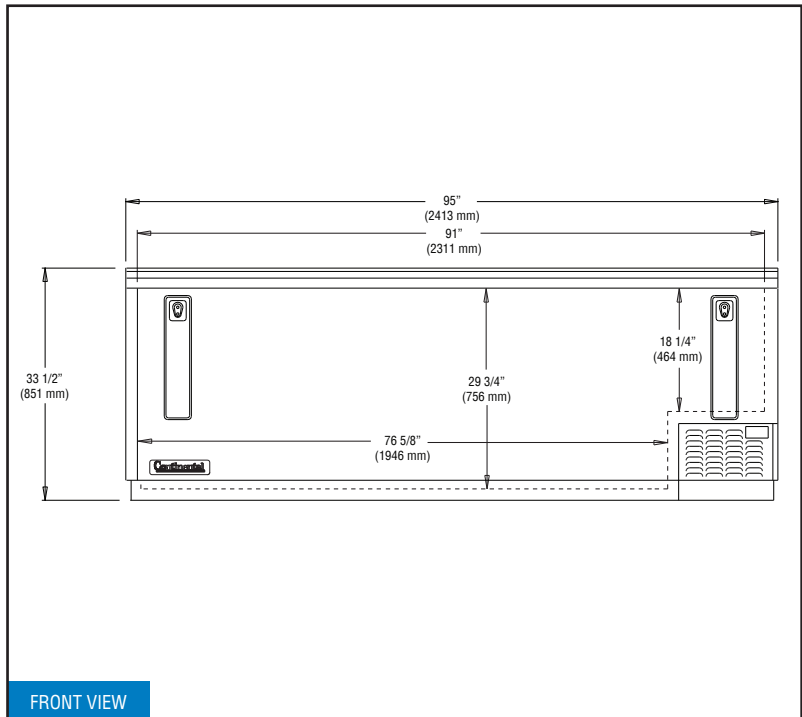

FRONT VIEW

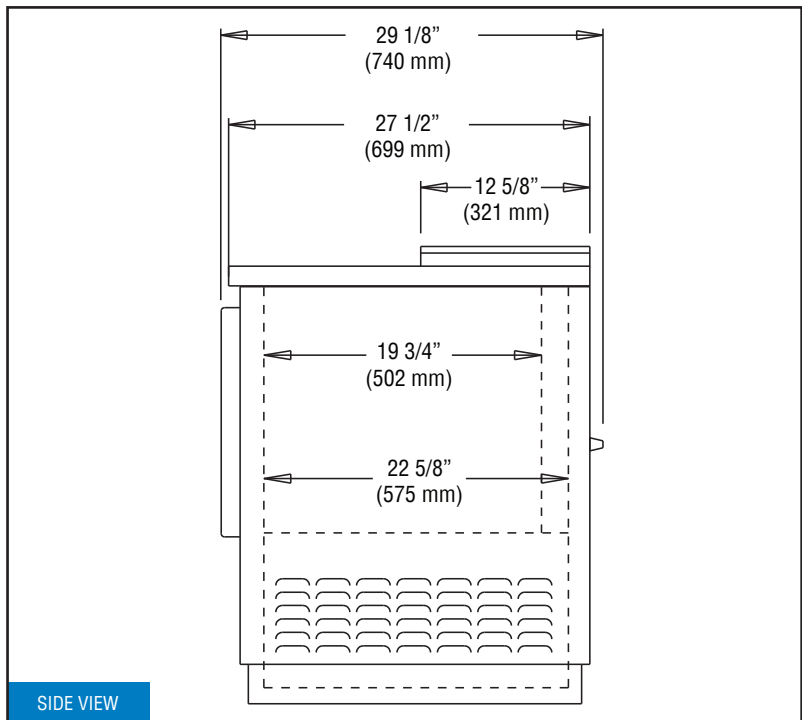

SIDE VIEW

IMPORTANT NOTE: A minimum clearance of 3" is required on each side, front and rear of cabinet for optimum performance.

REVISED: 5/16/2022